



Rekord





Rekord is designed and produced entirely to CE mark European standards.

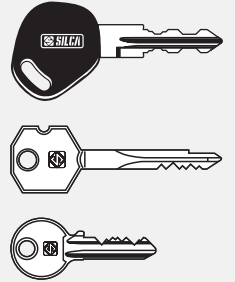

Rekord is the new Silca key cutting machine for cylinder keys for doors, vehicles and cruciform keys.

Duplicates with maximum precision and guarantees optimal working condition to the operator thanks to: high tech materials, ergonomic shapes, carriage movements by gears on a rectified carriage.

Compact machine dimensions, with optimised movements thanks to the innovative carriage transition lever position within the machine body

PLUS

- Sloping work surface
- Ergonomic handles and levers
- Compact dimensions
- Tools compartment
- Working tools area
- Led lamp
- Four face rotating jaws
- Adjustable tracer point
- Incorporated brush
- Carriage release lever

Rekord



Rekord



1 Tools compartment

A hinged compartment built into the body of the machine to keep all the maintenance tools safe and easy accessible.

2 Exclusive working tools area

Cover flat top, with anti slip coverage leaving space for keys, pins, tools in a useful and easily accessible working area.



6 Lamp

Powerful light in the working area thanks to an innovative led lamp integrated in the cover. Low energy consumption.

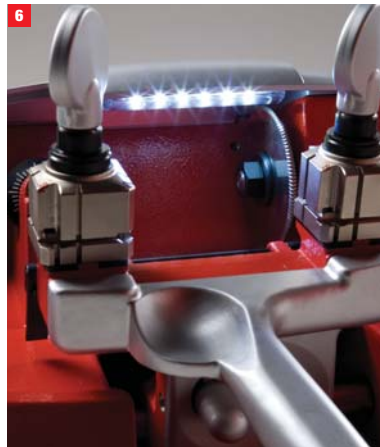

7 Brush

Convenient brush in top quality durable material, installed on the machine for finishing cut Keys.



3 Chippings tray

The inclination on the worktop ensures that the metal chips are conveyed directly into the tray.

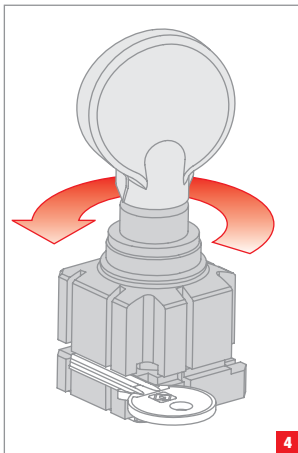

8 Handles and levers

New ergonomic handles and levers. Rounded shape with modern silver satin coverage, easy to grip and to clean thanks to the finished surface treatment.



4 Clamps

The clamps have four sides which rotate to allow the key to be perfectly secured on its back or in profile.

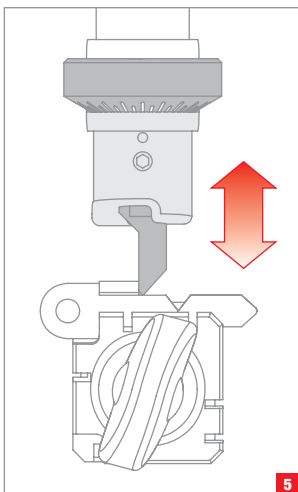

5 Tracer point

The tracer point easily ensures regulation of the depth thanks to a controlled pitch grub screw.





SILCA S.p.A.
 Via Podgora, 20 (Z.I.)
 31029 Vittorio Veneto (TV)
 Tel +39 0438 9136
 Fax +39 0438 913800
 E-mail: silca@silca.it
 www.silca.it

In the United Kingdom
Silca Ltd
 Kimpton Road - Sutton
 Surrey SM3 9QP
 Tel. +44 208 6416515
 Fax +44 208 6441181
 E-mail: sales@silcald.co.uk
 www.silcald.co.uk

In Germany
Silca GmbH
 Siemensstrasse, 33
 42551 Velbert
 Tel. +49 2051 2710
 Fax +49 2051 271172
 E-mail: info@silca.de
 www.silca.de

In France
Silca S.A.S.
 B.P. 37 - 12, rue de Rouen
 Z.I. de Porcheville
 78440 Porcheville
 Tel. +33 1 30983500
 Fax +33 1 30983501
 E-mail: info@silca.fr
 www.silca.fr

In Spain
Silca Key Systems S.A.
 C/Santander 73A
 08020 Barcelona
 Tel. +34 93 4981400
 Fax +34 93 2788004
 E-mail: silca@silca.es

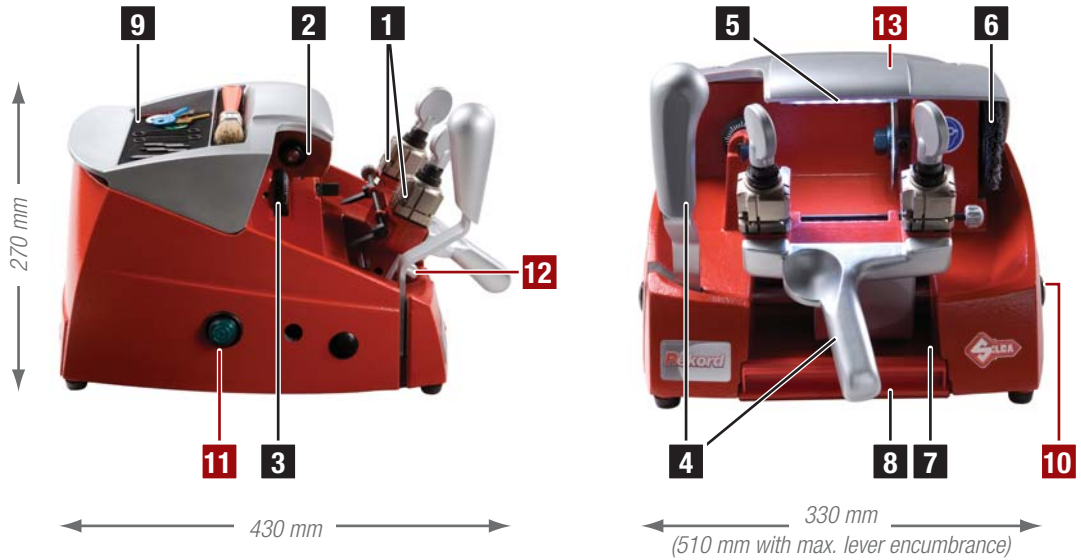

Technical Features

Rotating with four sides, high precision	1
HSS Super Rapid Steel Cutter	2
Controlled pitch grub screw	3
Ergonomic handles and levers	4
Innovative led lamp integrated in the cover	5
Incorporated brush	6
Chippings tray	7
Tools compartment	8
Working tools area (cover)	9

Security

Power switch	10
Motor (cutter and brush) on/off button	11
Carriage release lever	12
Cutter shield	13

Motor:	one-speed single phase - 230V-50Hz - 120V-60Hz
Movements:	by gear on rectified carriage
Maximum length of cuts:	43 mm (carriage run)
Dimensions:	Width: 330 mm (with max.lever encumbrance: 510 mm) Depth: 430 mm Height: 270 mm
Net weight:	19 Kg

www.silca.it



8 003737 691420

P771 DEPL. REKORD-GB

All information and illustrations in this documentation are for guidance only. Silca reserves the right to alter products designs, dimensions or info to improve the products quality. The contents of this documentation are fully protected by Copyright and may not be copied or reproduced in any form, without written permission from Silca. Any infringements will be dealt with under Italian law. In compliance with current regulations relating to industrial property, we hereby state that the trade-marks or trade names mentioned in our documentation are the exclusive property of authorized manufacturers of locks and users. Said trade-marks or trade names are mentioned in our documentation for the purposes of information so that any lock for which our keys are made can be rapidly identified. This documentation is reserved exclusively for professional key cutters who use Silca products.